

## Typennummer / Identification

Standard	Standard	<b>SFB 400/x</b>	Filter Typ	Type of filter	<b>3~ Sine Filter</b>
			Baureihe	Model Family	<b>SFB</b>





## Technische Daten / Technical Data

Phasenzahl	No. of phase				3
Schutzklasse	Protection class				III0
Schaltgruppe	Circuit Type				III
Bemessungsspannung Isolation	Rated voltage isolation	[ V ]			0 – 440 AC    0 – 520 AC
Überlagerte Schaltfrequenz	Ripple Frequency	[ kHz ]			3 – 8            4 – 8
Bemessungsfrequenz	Rated frequency	[ Hz ]			0 – 150        SFB 400/4 – SFB 400/150 0 – 60         SFB 400/180 – SFB 400/480
L Toleranz	L tolerance	[ % ]			± 10
Prüfspannung	Test voltage	[ kV ]			4.0            2 sec
Max. zulässige Motorleitungslängen (abhängig vom Umrichter-Typ)	Max. allowable length of the motor cables (depending on converter type)	[ m ]			Ca. 300 ( ungeschirmt / unshielded ) Ca. 200 ( geschirmt / shielded )

## Betriebsbedingungen / Operating conditions

Schutzart	Protection index				IP 00
Umgebungstemperatur	Ambient temperature	[ °C ]			-10.... +40
Lagertemperatur	Storage temperature	[ °C ]			-25 .... +70    ( EN 60721-3-1 ; 1K3 )
Transporttemperatur	Transport temperature	[ °C ]			-40 .... +85    ( EN 60721-3-2 ; 2K3 )
Überlastbarkeit	Overload capability				1.5-facher Nennstrom für 1 Minute pro Stunde / 1.5 times rated current for 1 minute per hour
Klimaklasse	Climatic category				25/085/21      ( EN 60068-1 )
Luftfeuchtigkeit	humidity				3K3 ( Ohne Betauung, mittlere relative Feuchte 85% ) ( Without condensation, medium relative humidity 85% )
Entflammbarkeitsklasse	Class of flammability				UL 94V-2 oder besser / UL 94V-2 or better
Temperaturklasse VDE	Class ISO °C VDE				H ( 180°C )
Temperaturklasse UL	Class ISO °C UL				Class 180
Kühlungsart	Type of cooling				AN
Betriebsart	Operating conditions				DB
Parallelschaltung	Parallel connection				Ja / yes        ( 90% Einzelbelastung ) / ( 90% Single load )
Überspannungskategorie	Overvoltage category				3 >2000m = 2    ( EN 61800-5-1 )
Rüttelfestigkeit	Vibration resistance				Transport 2M2    ( IEC/EN 60721-3-2 )
Verschmutzungsgrad	Degree of pollution				2                ( EN 61800-5-1 )
MTBF	MTBF	[ h ]			> 400.000 @ 40°C / 400V

## Ausführung / Standards

Typ / Type:	Datum / Date	Zeichen / Signs
EN 61558-1 +AC+A1 EN 61558-2-20	2005 + 2006 + 2009 2011	 
UL 5085-1-2 CSA 22.2 No. 6.6	2006, Edition 1	 E 219022 Only: SFB 400/4 – SFB 400/180
EAC	2015	
SJ/T 11363-2006 ( China-RoHS )	2006	
RoHS 2011/65/EU RoHS 2015/863/EU	2011 2015	

## Bemerkung / Notes

Die angegebenen technischen Daten sind typisch.  
Material- und fertigungsbedingt können Abweichungen auftreten.

Technical specifications are typical.  
They can vary due to material and production tolerances.

## Weitere Technische Daten / Other Technical Data

	Bemessungsstrom @ 480V	Linear bis Spitzenstrom	Induktivität L	Kapazität C Dreieckschaltung	Typ. Wicklungswiderstand	Kurzschlussspannung @ 400V & 50Hz	Verlustleistung Power Loss
	Rated current @ 480V	Linear up to	Inductance L	Capacitance C Delta connection	Typ. Winding resistance	Short circuit voltage @ 400V & 50Hz	Power Loss
	[ A ]	[ A ]	[ mH ]	[ µF ]	[ mOhm ]	[ % ]	[ W ]
SFB 400/4	4.0	6.0	11.0	1.5	253	6.0	50
SFB 400/10	10.0	15	5.10	3.3	75.2	7.0	100
SFB 400/16,5	16.5	24.8	3.07	3.3	32.7	6.9	110
SFB 400/23,5	23.5	35.3	2.50	3.3	32.1	8.0	125
SFB 400/32	32.0	48.0	2.00	3.3	16.1	8.7	140
SFB 400/37	37.0	55.5	1.70	3.3	14.3	8.6	210
SFB 400/48	48.0	72.0	1.20	3.3	7.28	7.8	240
SFB-N 400/61	61.0	91.5	1.00	7.05	5.42	8.3	280
SFB-N 400/72	72.0	108	0.95	7.05	5.32	9.3	300
SFB-N 400/90	90.0	135	0.80	7.05	3.03	9.8	290
SFB 400/115	115	172.5	0.70	7.05	3.25	11.0	460
SFB 400/150	150	225	0.50	14.1	2.20	10.2	530
SFB 400/180	180	270	0.40	14.1	1.50	9.8	580
SFB 400/250	250	375	0.35	22.5	1.33	11.9	810
SFB 400/440	440	660	0.14	47.0	0.69	8.4	1400
SFB 400/480	480	720	0.14	66.0	0.69	9.1	1550

## Temperaturreduzierung / Derating

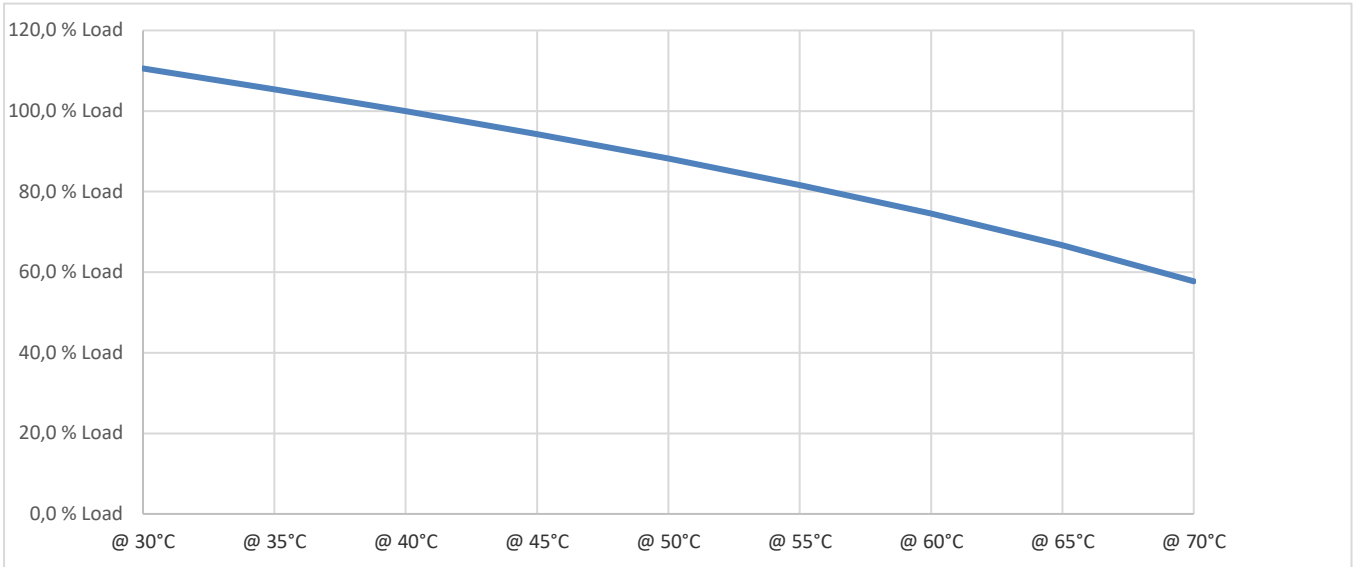

## Leistungsreduzierung / Power reduction

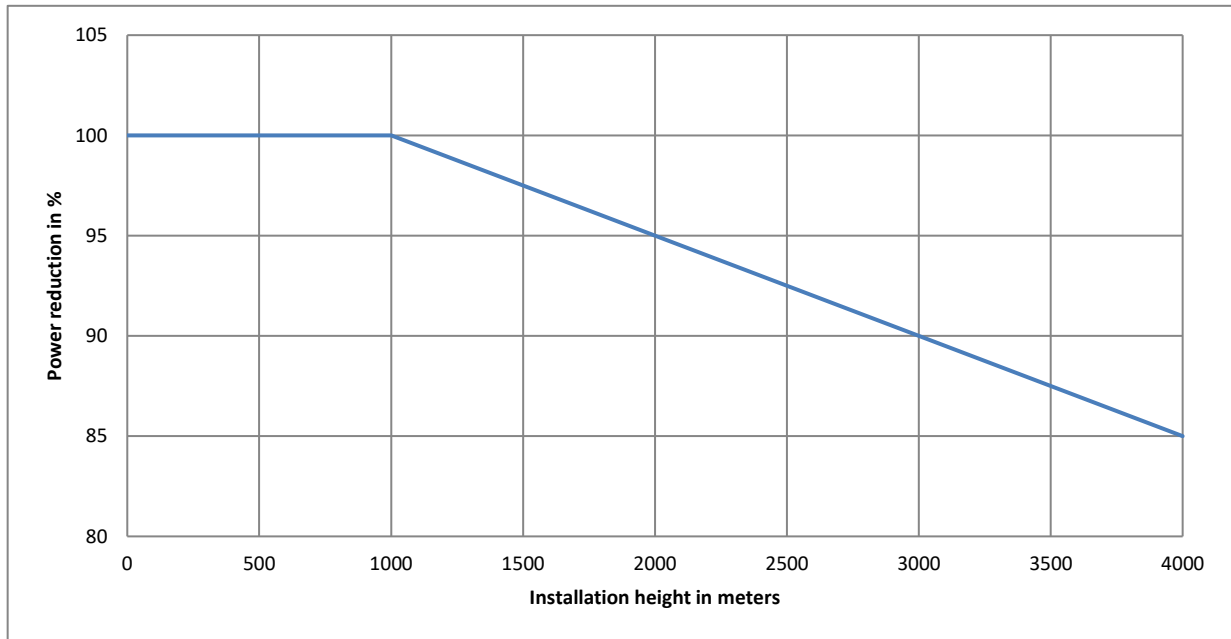

Aufbauskizze / Construction drawing

1:

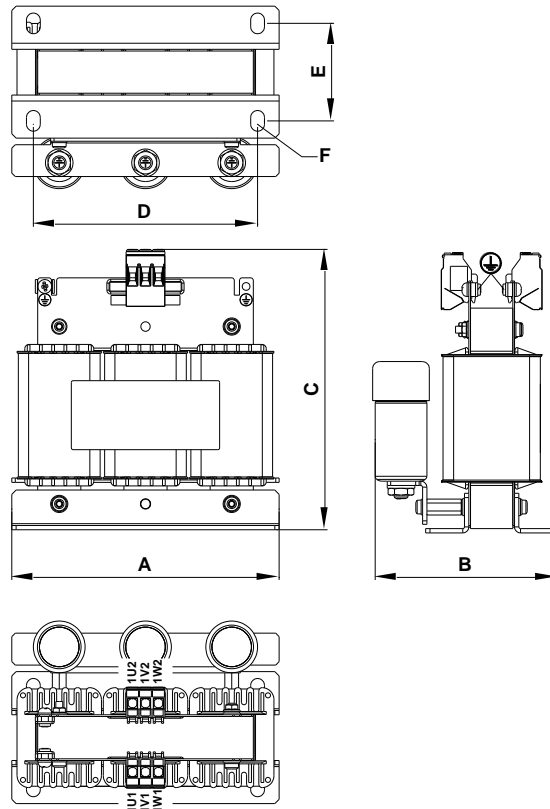

2:

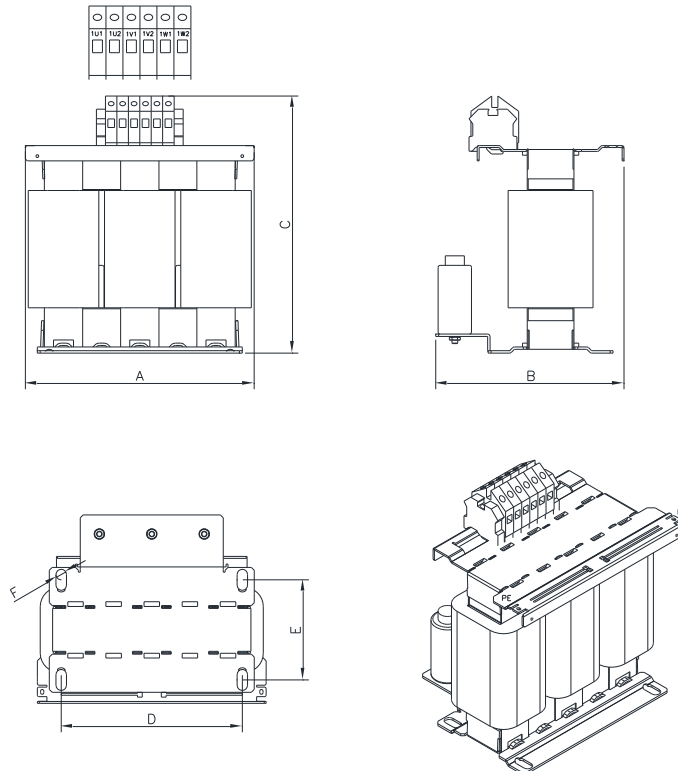

Aufbauskizze / Construction drawing

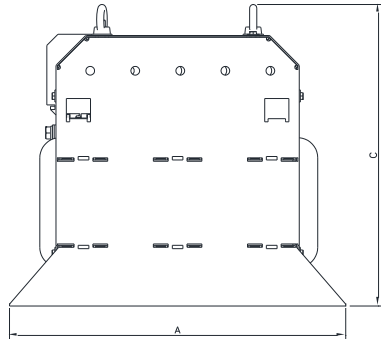

3:

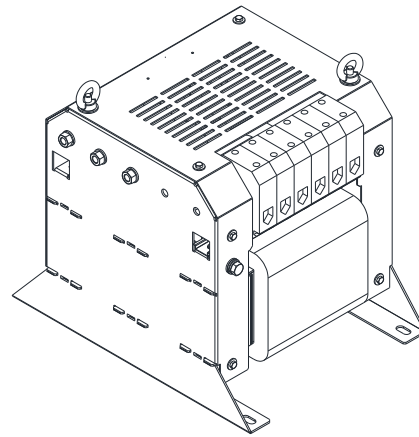
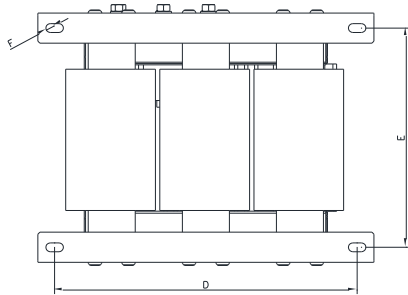
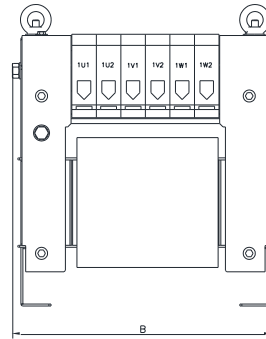

Abmessungen / Dimensions

	Aufbauskizze Construction drawing	A	B	C	D	E	F
		[ mm ]	[ mm ]	[ mm ]	[ mm ]	[ mm ]	[ Ø ]
SFB 400/4	1	155	110	165	130	56.5	8.0
SFB 400/10	1	155	125	165	130	71.5	8.0
SFB 400/16.5	1	190	160	195	170	67	8.0
SFB 400/23.5	2	240	190	280	190	95	11
SFB 400/32	2	240	200	280	190	105	11
SFB 400/37	2	240	210	280	190	115	11
SFB 400/48	2	240	220	280	190	125	11
SFB-N 400/61	2	300	228	315	240	133	11
SFB-N 400/72	2	300	250	320	240	145	11
SFB-N 400/90	2	300	270	320	240	171	11
SFB 400/115	2	360	220	420	264	124.5	10
SFB 400/150	2	360	225	422	264	140	10
SFB 400/180	2	360	235	444	264	155	10
SFB 400/250	3	500	400	450	450	325	13

Aufbauskizze / Construction drawing

SFB 400/440

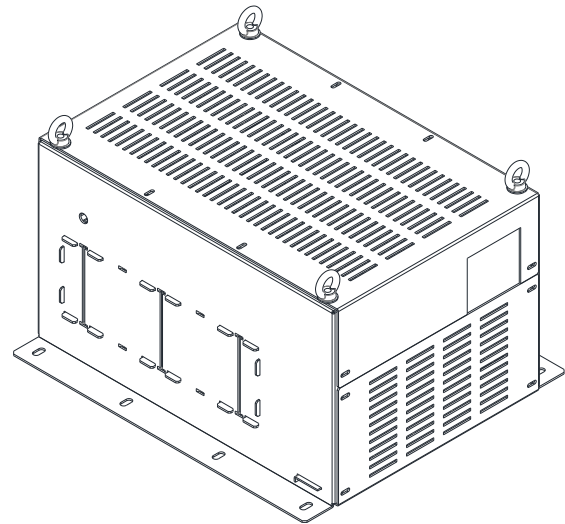
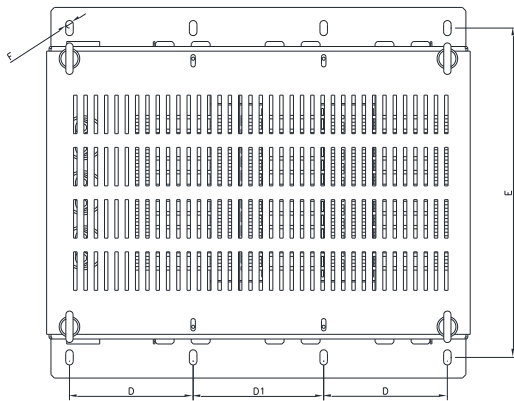
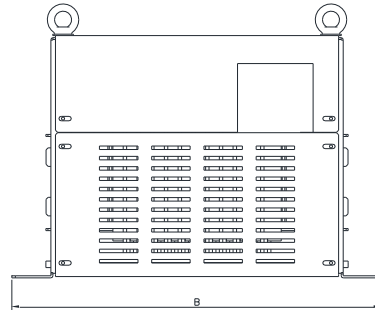
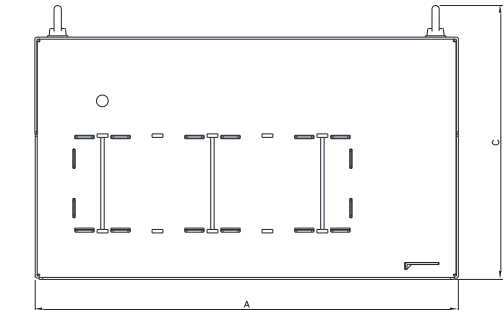

Abmessungen / Dimensions

	A	B	C	D	D1	E	F
	[ mm ]	[ mm ]	[ mm ]	[ mm ]	[ mm ]	[ mm ]	[ Ø ]
SFB 400/440	<b>627</b>	<b>532</b>	<b>398</b>	<b>180</b>	<b>190</b>	<b>472</b>	<b>11</b>

Aufbauskizze - Abmessungen / Construction drawing - Dimensions

SFB 400/480

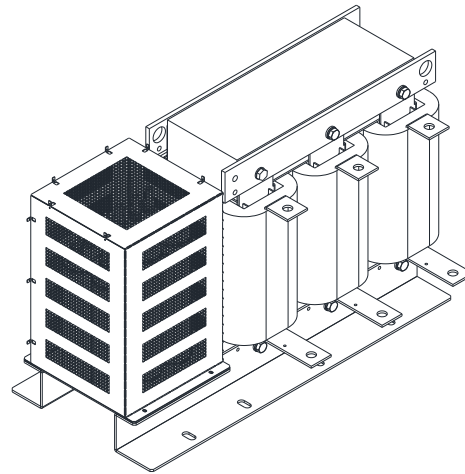
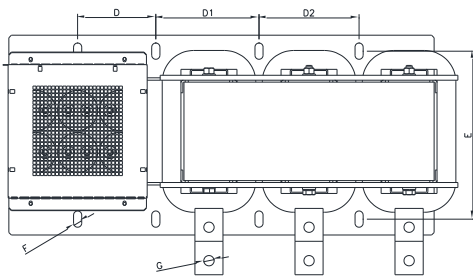
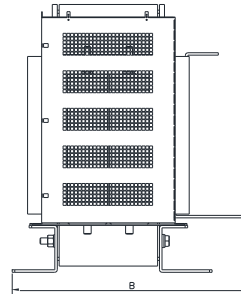
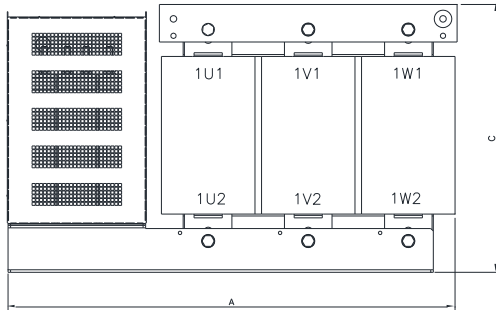

Abmessungen / Dimensions

	A	B	C	D	D1	D2	E	F	G
	[ mm ]	[ mm ]	[ mm ]	[ mm ]	[ mm ]	[ mm ]	[ mm ]	[ Ø ]	[ Ø ]
SFB 400/480	730	370	410	125	165	160	266.5	13.0	16.5

**Zusätzliche Informationen / Additional Information**

	Anschlüsse / Terminals			Anzugsmomente / Torque			-	
	Schraubklemme	Kupferanschluss	PE-Anschluss	Schraubklemme	Kupferanschluss	PE-Anschluss	Gewicht (Netto)	Wickelmaterial
	Screw terminal	Copper connection	PE Terminal	Screw terminal	Copper connection	PE Terminal	Weight (Net)	Winding material
	[ mm <sup>2</sup> ]	[ mm ]	-	[ Nm ]	[ Nm ]	[ Nm ]	[ kg ]	-
SFB 400/4	4.0	-	M4	0.5 – 1.0	-	1.8	4.0	CU
SFB 400/10	4.0	-	M4	0.5 – 1.0	-	1.8	6.1	CU
SFB 400/16.5	10.0	-	M4	1.2 – 2.0	-	1.8	9.5	CU
SFB 400/23.5	16.0	-	M6	2.0 – 4.0	-	6.0	14.4	CU
SFB 400/32	16.0	-	M6	2.0 – 4.0	-	6.0	19.7	CU
SFB 400/37	16.0	-	M6	2.0 – 4.0	-	6.0	21.3	CU
SFB 400/48	16.0	-	M6	2.0 – 4.0	-	6.0	26.2	CU
SFB-N 400/61	35.0	-	M6	2.5 – 5.0	-	6.0	35.0	CU
SFB-N 400/72	50.0	-	M6	6.0 – 8.0	-	6.0	39.0	CU
SFB-N 400/90	50.0	-	M6	6.0 – 8.0	-	6.0	53.5	CU
SFB 400/115	95.0	-	M8	8.0 – 12.0	-	12.0	67.5	CU
SFB 400/150	95.0	-	M8	8.0 – 12.0	-	12.0	79.0	CU
SFB 400/180	150.0	-	M8	14.0 – 20.0	-	12.0	88.7	CU
SFB 400/250	240.0	-	M12	10.0 – 20.0	-	30.0	157.5	CU
SFB 400/440	-	30 x 5	M16	-	60.0	60.0	192.5	CU
SFB 400/480	-	45 x 4	M10	-	60.0	20.0	220.0	CU

**Zusatzinformationen Klemmen / Additional Information Terminals**

Klemme	Terminal	[ mm <sup>2</sup> ]	4	10	16	35	50	95	150	240	Schraubklemme / Screw Terminal
Eingang Ausgang	Input Output	[ mm <sup>2</sup> ]	0.2 – 6.0	0.2 – 16	2.5 – 25	2.5 – 50	16 – 50 / 25 – 50	25 – 95	35 – 150	70 – 240	Eindrähtig ( starr ) / Mehrdrähtig Single wire ( solid ) / stranded
		[ mm <sup>2</sup> ]	0.2 – 6.0 0.2 – 4.0	0.2 – 10	2.5 – 25 2.5 - 16	2.5 – 35	25 – 50	25 – 95	35 – 150	70 – 240 / 70 – 185	Flexibel / Flexibel mit Aderendhülse Flexible / flexible with cable and sleeves
		AWG	22 – 10	22 – 10	10 – 6	12 – 2	6 – 1/0	2 – 4/0	300 – 2	2/0 – 500	
		[ mm ]	9	14	15	20	27	30	38	38	Abisolierlänge / Stripping length
		-	Schlitz / Slotted	Schlitz / Slotted	Schlitz / Slotted	Schlitz / Slotted	Innen- sechskant / Hexagon socket	Innen- sechskant / Hexagon socket	Innen- sechskant / Hexagon socket	Innen- sechskant / Hexagon socket	Schraubenkopf / Screw head
-		M3	M4	M5	M6	M6	M8	M8	M10	Schraubengewinde / Screw threading	

**Einbaulage / Mounting directions**

Die Einbaulage der Sinusfilter muss stehend erfolgen.  
Bei anderen Einbaulagen ist Rücksprache zu halten

The Mounting directions all Sine filter must be standing position.  
For any other position please consult.

**Bemerkung / Notes**

Einzelheiten der Darstellung in der Aufbauskitze sind unverbindlich.  
Allgemeintoleranzen DIN 2768-m.  
Änderungen vorbehalten.

Technical specifications in the drawing are not binding.  
General tolerance to DIN 2768-m.  
Subject to change.

## Freiräume / Free spaces

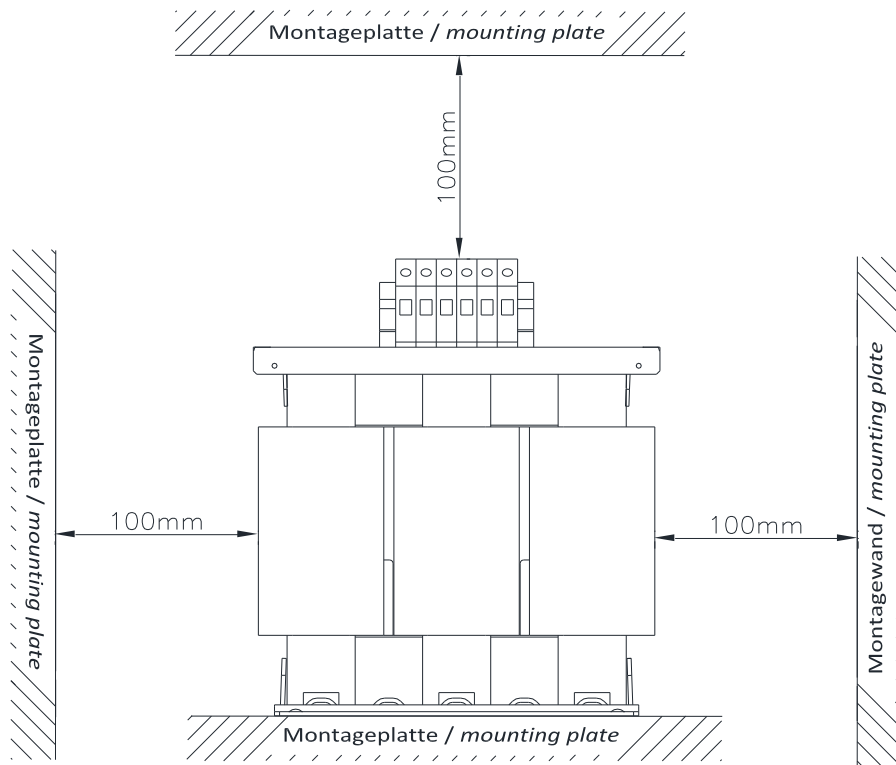

## Sicherheitshinweise / Notes

Bitte lesen Sie diese Warnungen und Sicherheitshinweise sorgfältig durch, bevor Sie das Gerät in Betrieb nehmen. Das Gerät darf nur durch fachkundiges und qualifiziertes Personal installiert werden. Bei Funktionsstörungen oder Beschädigungen schalten Sie sofort die Versorgungsspannung ab und senden das Gerät zur Überprüfung ins Werk. Das Gerät beinhaltet keine Servicebauteile. Bei Auslösen einer internen Sicherung liegt höchstwahrscheinlich ein interner Defekt am Gerät vor. Die angegebenen Daten dienen allein der Produktbeschreibung und sind nicht als zugesicherte Eigenschaften im Rechtssinne aufzufassen.

**Bestimmungsgemäßer Gebrauch**

Dieses Gerät ist für den Einbau in ein Gehäuse konzipiert und zur Verwendung für allgemeine elektronische Geräte, wie z.B. Industriesteuerungen, Bürogeräte, Kommunikationsgeräte oder Messgeräte geeignet. Benutzen Sie dieses Gerät nicht in Steuerungsanlagen von Flugzeugen, Zügen oder nuklearen Einrichtungen, in denen eine Funktionsstörung zu schweren Verletzungen führen oder Lebensgefahr bedeuten kann.

**Installation**

Die Installation ist entsprechend den örtlichen Gegebenheiten, einschlägigen Vorschriften, nationalen Unfallverhütungsvorschriften und den anerkannten Regeln der Technik durchzuführen. Dieses elektrische Betriebsmittel ist eine Komponente, die zum Einbau in elektrische Anlagen oder Maschinen bestimmt ist und erfüllt die Anforderungen der Niederspannungsrichtlinie (2014/35/EU). Der geforderte Mindestabstand zu benachbarten Teilen ist einzuhalten, um die Kühlung nicht zu behindern!

Please read these warnings and safety notices carefully before operating the device. Installation of the device is reserved for competent and qualified personnel. In the event of malfunctions or damage to the device, switch off the supply voltage immediately and send to the production plant for inspection. The device does not contain any service parts. The specified data serve the product description alone and are not understood as warranted characteristics in the legal sense.

**Proper use**

This device is designed for installation in a wiring cabinet and for general use with a frequency inverter such as industrial control systems, machine tools, wind turbines and elevators for example. Do not use this device in the control systems of aircraft, trains, or nuclear facilities where malfunction may result in severe injury or death.

**Installation**

Installation should be performed in accordance with local conditions, relevant provisions, national accident prevention regulations and the accepted rules of engineering. This electrical equipment is a component designed for installation in electrical systems or machines and it satisfies the requirements of the Low Voltage Directive (2014/35/EU). The required minimum distance from the adjacent parts must be maintained in order to prevent the cooling system from being impeded!